

SWP09 | CCT SLIM WALL PACK

Project: _____ Type: _____

Name: _____ Date: _____



Size	13.8" W x 8.8" H x 4.6" D 17.8" W x 12.7" H x 4.6" D	Lumens	7,800-8,400lm 15,600-16,800lm
Watts	60W, 120W	CCT	3000K-4000K- 5000K
Voltage	120-277V	IP Rating	IP65
Dimming	0-10V	Materials	Aluminum, Glass
Beam Angle	110°	Finish	Bronze
CRI	>80	Lens	Clear
PF	≥ 0.9	Lifespan	50,000 Hours

OVERVIEW

CCT: Tunable

Applications: Indoor Outdoor (IP)

Efficacy: 125-135lm/W

Dimming: 0-10V

LED Type: SMD 2835

Lens Type: Clear

Driver: BOE120C-130-PVF-Z

Operating Temp: -40F° to 113F°

Operating Humidity: 20% - 90% RH

Lifespan: 50,000 Hours

Warranty: 5 Years

FEATURES

- Photocell Light Sensor automatically activates the lights when dark
- Bright and uniform, instant start, non-flickering, non-humming LEDs

SARIN LED CCT SLIM WALL PACKS light up your outdoor spaces in rain, snow and darkness with bright and high quality LEDs. These wall packs are built to run for long periods and save you money through energy efficiency and far fewer replacement intervals. These fixtures also feature a photocell light sensor that automatically switches the unit on or off depending on the amount of light it detects.

This wall pack adopts the latest technology, replacing traditional bulbs with energy efficient LEDs. These are widely used in the lighting of homes, hotels, garages, streets, landscapes and other commercial spaces. Wall Pack lights are popular in entryways, for general area lighting, perimeter lighting, and storage facilities. These fixtures are suitable for a variety of applications and will provide significant energy savings.



SWP09 | CCT SLIM WALL PACK

Project: _____ Type: _____

Name: _____ Date: _____

DIMENSIONS:

60W:

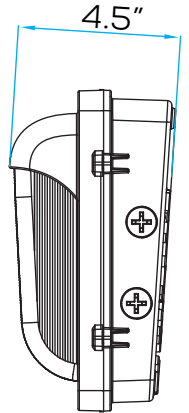
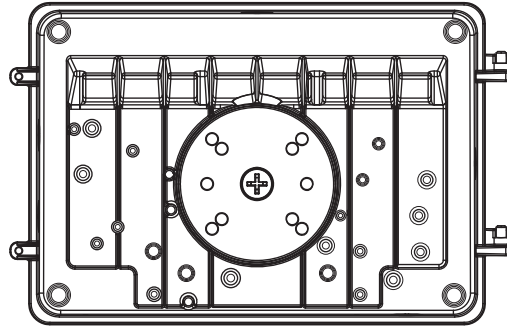
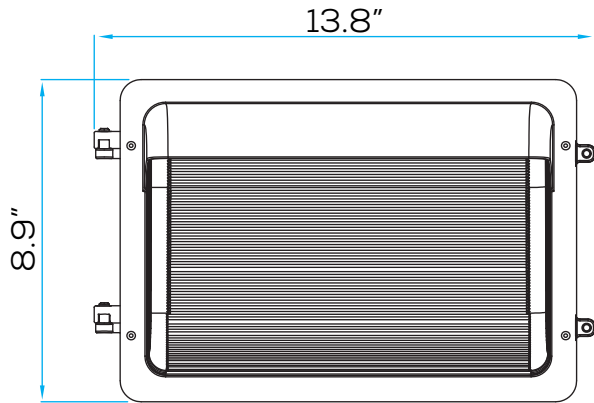

120W:

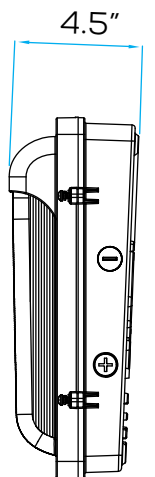
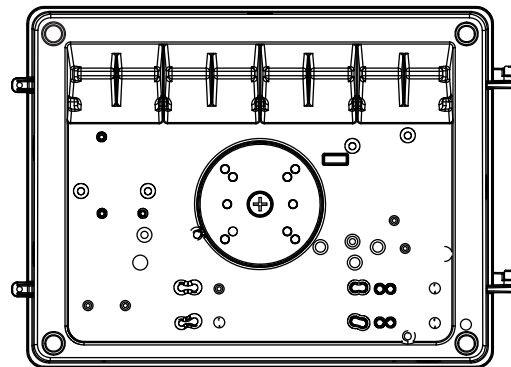
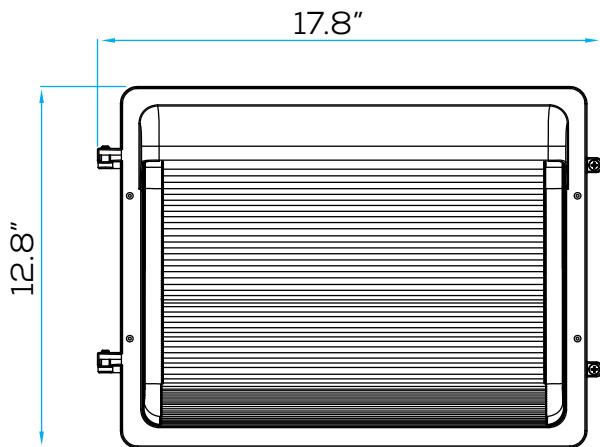

SWP09 | CCT SLIM WALL PACK

Project: _____ Type: _____

Name: _____ Date: _____

ORDER FORM:

(*) Special Order/Not Commonly Stocked

Custom Model Assembly

	Fixture	CCT	Watts	Beam Angle	Voltage
	<input checked="" type="checkbox"/> SWP09	<input checked="" type="checkbox"/> Tunable	<input type="checkbox"/> 60W <input type="checkbox"/> 120W	<input checked="" type="checkbox"/> 110°	<input checked="" type="checkbox"/> 120-277V
<hr/>					
SES-SWP09-CCT-60W					
Example Model Number					

SES – SWP09 – Tunable – 110° – 120-277V

Quantity

Fixture

CCT

Watts

Beam Angle

Voltage

Common Stock Models:

Item #	Model #
11338	SES-SWP09-CCT-60W
11339	SES-SWP09-CCT-120W